

THE GALLEY®





Installation Guide

Ideal HydroStation™

Ideal HydroStation²

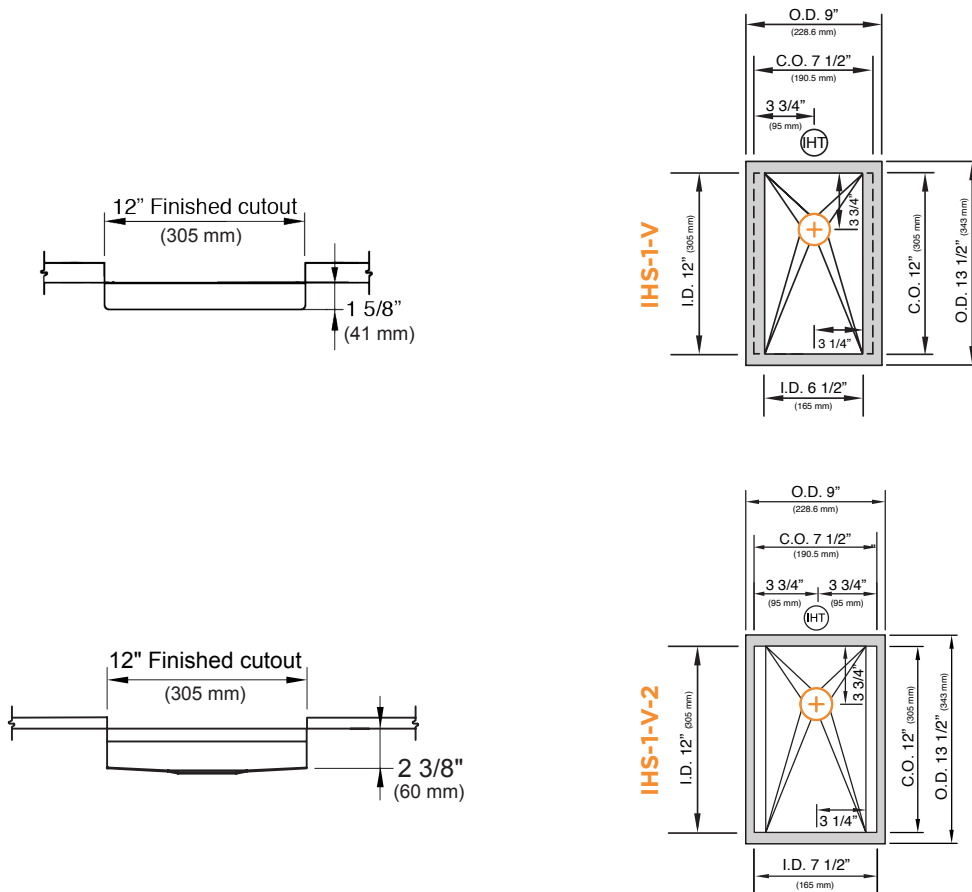
HydroStation™ & HydroStation²



 H-DRN (provided) has 2" diameter drain opening with 1 1/2" outlet

IMPORTANT

Please note The Galley HydroStation is a partially positive reveal basin with specific cutout dimensions outlined in this guide and the supplied template tray. The HydroStation requires a minimum 16 1/2" depth cabinet for installation.

Inspect The Galley HydroStation for any damage prior to installation. For any questions or concerns please contact us immediately at 800.375.4255 or customerservice@thegalley.com.

Please refer to all local plumbing and building codes prior to installation.

Tools



WATER PROOF SILICONE



GRANITE ADHESIVE



2" PAINTERS TAPE



PAPER TOWELS



BASIN CLIPS (PROVIDED)

Installation

Use the white template tray affixed to The Galley HydroStation flanges as your guide for the overall cutout for either vertical or horizontal installation. The 1/2" reveal along the length of the basin allows for the Tools to slide across the exposed flange.

The suggested maximum corner radius is 3/8". *Please refer to countertop manufacturer's warranted minimums*

**YOU ARE NOW READY
FOR THE COUNTERTOP
FABRICATOR**

Countertop Installation

STEP 1

With the HydroStation properly in place over the countertop cutout, place the clips evenly around the basin on all four sides. Mark your placement on each clip.

STEP 2

Fill your marked area with an even 1/4" thick bead of adhesive and then place the clip mount on the area and press firmly into place. Let the adhesive cure according to the manufacturer's specifications.

STEP 3

Cover what will be the exposed 1/2" of the left and right flanges with painters tape for easy cleaning of excess silicone.

STEP 4

Apply a heavy bead of silicone to the un-taped portion of the flanges and carefully place the HydroStation onto your cutout and position so that there is a 1/2" reveal on the left and right flanges. Place the washer and wing nut on the mounting clip studs and hand tighten firmly.

STEP 5

Wait one hour and remove the painters tape. This will ensure there is a clean flange, free from silicone. This will enable the Tools to slide freely.

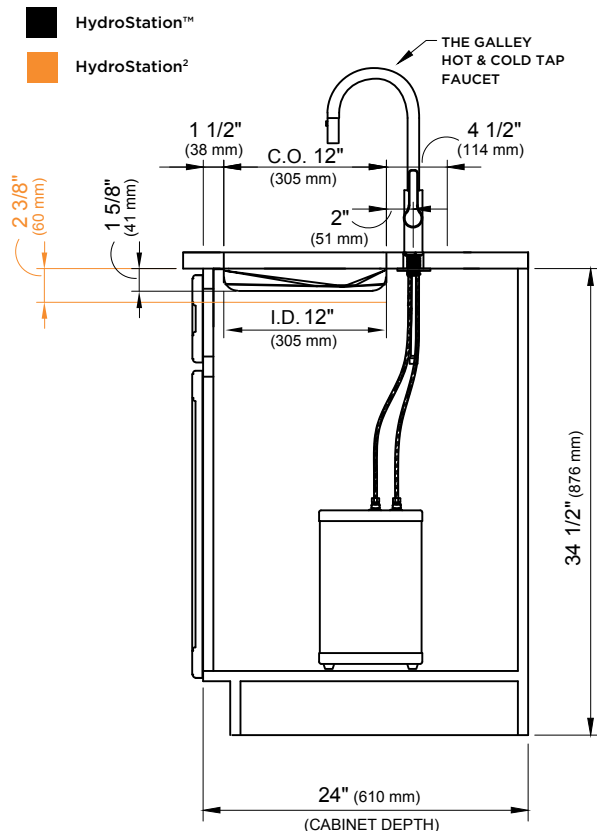

The Galley Workstation® Limited Lifetime Warranty

1. GALLEY WORKSTATION LIMITED LIFETIME WARRANTY - Seller provides a Limited Lifetime Warranty. Seller warrants its stainless steel sink, installed in a residential application, to be free from manufacturing defects in materials and workmanship under normal residential usage. This Limited Lifetime Warranty is subject to the warranty conditions and limitations as set forth below.

2. WARRANTY CONDITIONS AND LIMITATIONS - Seller's warranty is non-transferable and is strictly limited to products correctly installed using our installation instructions and used in a residential environment. This warranty is limited to defects or damages resulting from normal residential use and does not cover surface corrosion, (chemical or natural, including exposure to salt air, sea spray, acid rain, or environmental chemicals), scuffs or scratches, misuse, abnormal or abusive use, dents, deformations caused by the impact of any object, improper installation, care and/or maintenance, commercial use, environmental factors causing damage, shipping or freight damage, or common signs of normal wear and tear, (scratching, staining and alkaline etching of the finish over time due to use, cleaning practices or water or atmospheric conditions, are not manufacturing defects but are indicative of normal wear and tear however, these symptoms are easy to remedy). This limited warranty is null and void if the Product has been repaired, altered, or modified other than by Seller or under Seller's supervision. The Seller is not responsible for labor charges, installation or other incidental or consequential costs. In no event shall the liability of Seller exceed the purchase price of the product. If the product is installed outside of North America, Seller warrants product to be free from defects in material and workmanship for one (1) year from the date the product is installed, with all other terms of this warranty applying except duration. If the product has not been purchased from Seller or from an Authorized Dealer or Distributor of the Seller, this warranty is null and void.

3. CULINARY TOOLS - The Culinary Tools are not warranted. If a defect is found in normal residential use, Seller will, at its election, repair, replace or make appropriate adjustment. All items made of Natural Golden Bamboo or Walnut should not have prolonged exposure to direct sunlight or be stored outdoors.

4. CARE AND MAINTENANCE - For care and maintenance instructions of all Galley products, please refer to the Use and Care section on thegalley.com.

5. WARRANTY CLAIMS - These warranties are in effect for Seller's Products purchased on January 1st, 2015 and thereafter. For warranty claims, please contact your Authorized Galley Dealer, or you may write to:

The Galley, LLC.
Attn: Warranty Claims
12626 South Memorial Drive
Bixby, OK 74008

Please include the original receipt with a description of the problem, model number, store, date of purchase, your name, address and telephone number.

THE GALLEY®
■ ■ ■ ■

Corporate Headquarters

The Galley, LLC
12626 South Memorial Drive
Bixby, OK 74008
800.375.4255
thegalley.com