

# THE **GALLEY** TAP®



## Soap Dispenser Installation Guide

ISD-1

# Parts Included

- |                     |                    |                |
|---------------------|--------------------|----------------|
| A. Dispenser sleeve | C. Base ring       | G. Soap bottle |
| B. Threaded body    | D. Rubber gasket   | H. Tubing      |
|                     | E. Mounting washer |                |
|                     | F. Mounting nut    |                |

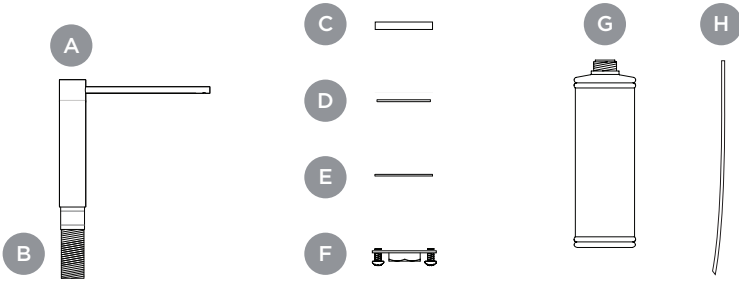

# Required Tool



#2 PHILLIPS SCREWDRIVER

# Installation

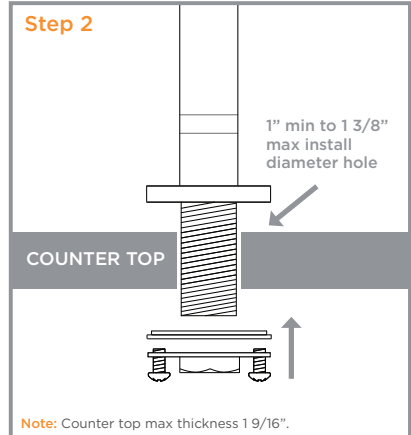
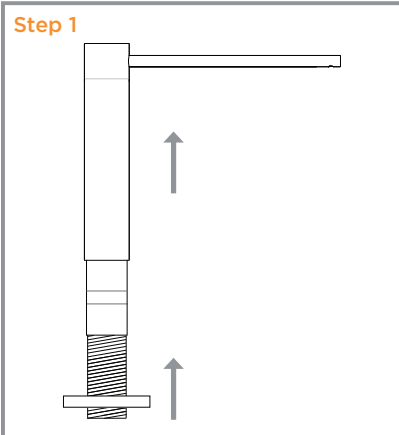

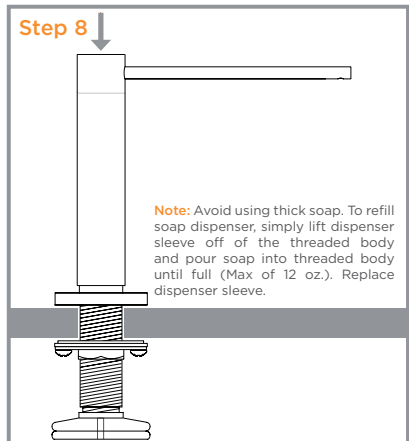
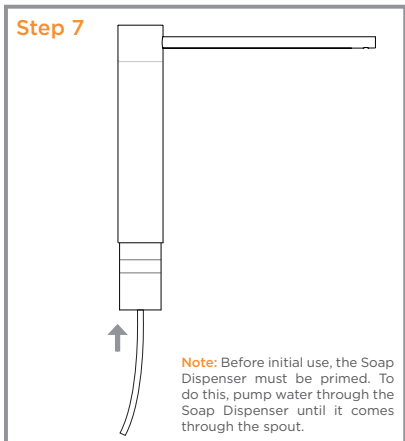
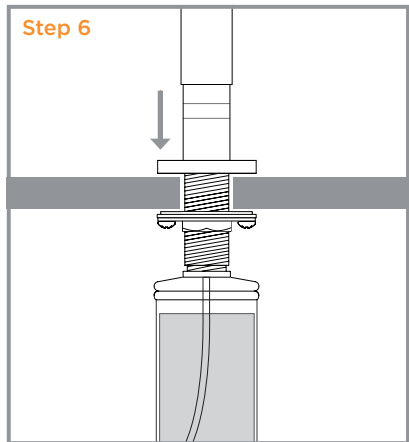
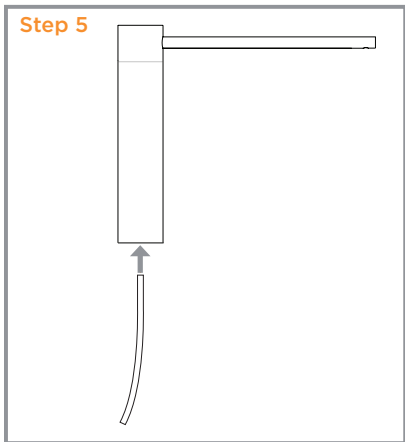
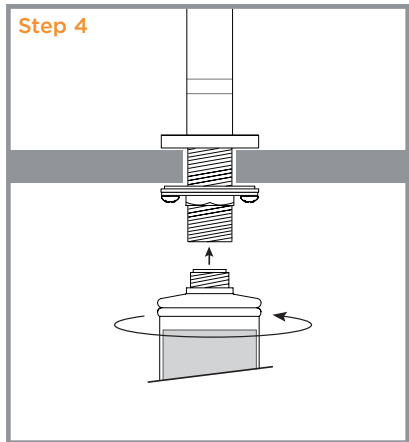
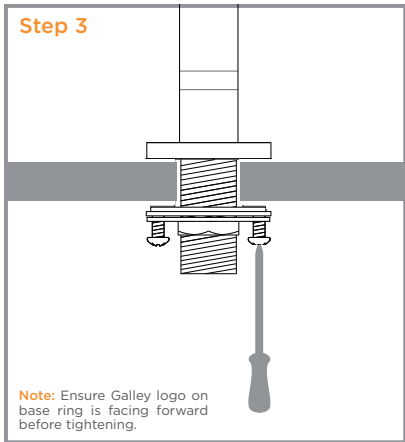

# The Galley Tap - Limited Lifetime Warranty

## 1. GALLEY TAP LIMITED LIFETIME MECHANICAL WARRANTY —

Seller provides a Limited Lifetime Mechanical Warranty. Seller warrants its products, installed in a residential application, to be free from manufacturing defects in materials and workmanship under normal usage for the useful life of the product. This Limited Lifetime Mechanical Warranty is subject to the warranty conditions and limitations as set forth below.

## 2. GALLEY TAP LIMITED LIFETIME FINISH WARRANTY —

Seller provides a Limited Lifetime Finish Warranty. For the following Finishes: Polished Stainless Steel, Matte Stainless Steel, PVD Satin Black Stainless Steel, PVD Gun Metal Gray™ Stainless Steel, PVD Polished Rose Gold Stainless Steel and PVD Brushed Gold Stainless Steel, seller warrants its finishes, installed in a residential application, to be free from manufacturing defects in materials or workmanship for the useful life of the product. Please refer to the Seller's Care Instructions for the proper maintenance of Seller's finishes. This Limited Lifetime Finish Warranty is subject to the warranty conditions and limitations as set forth below.

## 3. WARRANTY CONDITIONS AND LIMITATIONS —

Seller's Mechanical and Finish warranties are non-transferable and are strictly limited to products correctly installed using our installation instructions and used in a residential environment. Mechanical or finish problems which result from abuse, misuse, improper installation, improper maintenance, (including not properly winterizing the Tap in outdoor installations), improper cleaning, proximity to bodies of saltwater, or accidental damage such as scuffs and scratches are not covered by this warranty. Seller does not assume liability for labor charges, removal and reinstallation expenses, freight or postage charges, or injuries resulting from a defective product. This warranty does not allow recovery of incidental or consequential damages such as loss of use, property damage, or any other consequential damage and Seller accepts no liability for such damage. Seller does not assume any responsibility other than to repair or replace the defective part(s) after Seller, upon its examination, has determined the product to be defective and the defective part(s) are covered by the Limited Lifetime Warranty expressed in this warranty. Whether to repair or replace the product shall be at the sole election of the Seller. In no event shall the liability of The Galley exceed the purchase price of the Tap. The use of Plumber's Putty will void this warranty. A non-corrosive epoxy silicone sealing compound may be used. Seller hereby disclaims all other warranties, expressed or implied, other than those set forth in this warranty. Some states do not allow the exclusion or limitation of incidental or consequential damages, so the above limitation or exclusion may not apply to you. This warranty gives you specific legal rights and you may also have other rights which vary from state to state.

## 4. CARE AND MAINTENANCE —

For care and maintenance instructions of all Galley products, please refer to the Use and Care section on [thegalley.com](http://thegalley.com).

## 5. WARRANTY CLAIMS —

These warranties are in effect for Seller's Products purchased on January 1st, 2017 and thereafter. For warranty claims, please contact your Galley Dealer, or you may write to:

**The Galley, LLC.**  
**Attn: Warranty Claims**  
**12626 South Memorial Drive**  
**Bixby, OK 74008**

*Please include the original receipt with a description of the problem, model number, store, date of purchase, your name, address and telephone number.*



## Corporate Headquarters

The Galley, LLC.  
12626 South Memorial Drive, Bixby, OK 74008  
800.375.4255 | [thegalley.com](http://thegalley.com)