

Ideal Workstation. 2C

SPECIFICATIONS

IWS-2-C-BA

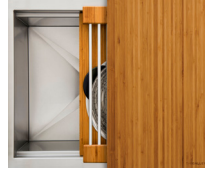

Natural Golden Bamboo

IWS-2-C-GT



Graphite Wood Composite

IWS-2-C-WH



Designer White Resin*

IWS-2-C-GR



Exclusive Gray Resin*

Specifications

Single bowl
Users: 1
Culinary Tools included: Five
Galley BarTap® recommended: One
Outside dimensions: 22" x 19 1/2" x 10 5/16"
Countertop cutout: 21" x 18"
Basin area: 20 1/2" x 16"
Minimum cabinet size: 24" or 60cm

Basin (KSO-2-C-SS)

16GA 316L stainless steel indoor/outdoor
SilentArmor™ sound reduction technology
Angel finish
Two tier design
Star™ groove pattern
Center drain
Drain cover included
Limited Lifetime Warranty
Made in the USA
ASME A112.19.3/CSA B45.4 certified

Culinary Tools included (CKT-12)



(1) Upper Deck
Section†
12" x 19"
UD-12-I-xx



(1) Upper Tier
Drying Rack
12 1/4" x 18"
DR-12-U-xx



(1) Upper Tier
Cutting Board
12 1/4" x 18"
CB-12-U-xx



(2) Lower Tier
Platforms
12 1/4" x 17"
P1-12-L-xx



(1) Stainless Steel
Colander
11" 7.2-qt
C1-11-0-ST



(1) Stainless Steel
Mixing Bowl
11" 7.2-qt
B1-11-0-ST

Personalize Your IWS-2-C

Add 7-12" length
Add 1-6" length
Add 18" DryDock
Add 12" DryDock

Apron front
9" height

Galley Tap collection
Optional Culinary Tools
*Color coded labels available

† The Upper Deck requires a 1/4" clearance below the surface of the countertop. If the countertop thickness is 2cm or less, Bamboo Upper Deck sections will not have the needed clearance to function above the Upper Tier Culinary Tools.

Please refer to Culinary Kit Finish descriptions for planning.

Custom options are available for countertops that are 1/2" or less in thickness.

Upper Deck™

Upper Deck cover set **UD-2-2P-GT/BA/GR/WH** Graphite, Bamboo, Gray or White Resin

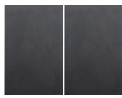

12" 12"



(1) 12"

Included in CKT

Upper Deck sections Graphite, Bamboo, Gray or White Resin

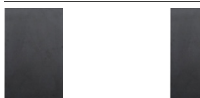

UD-12-I-GT/BA/GR/WH UD-06-I-GT/BA/GR/WH

Recommended Basin Accessories

Bottom Grate set **BG-2-C-1-SS** Stainless Steel



20"

Manual Strainer Basket

M-DRN-MSS Angel Finish 304 Stainless Steel



Disposal Flange Strainer Basket

G-DRN-MSS Angel Finish 304 Stainless Steel



Auto Strainer Basket Angel Finish 304 Stainless Steel with Polished or Matte knob



A-DRN-MSS shown

A-DRN-PSS
A-DRN-MSS

Ideal Workstation. 2C

SPECIFICATIONS

Tap Hole Specifications

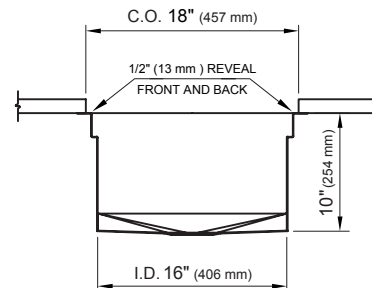
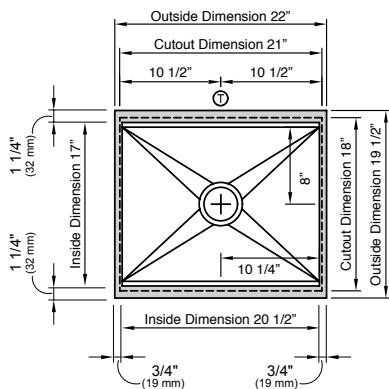

SUGGESTED GALLEY TAP PLACEMENT GUIDE

Suggested maximum inside corner radius of countertop cutout 3/8"

① Galley BarTap- 1 3/8" min to 1 1/2" max hole diameter

Center Tap hole diameters 2" behind cutout

Note: Galley Hot & Cold Tap requires a minimum 8" clearance to center if installed to the right of the Galley Tap

Call 800.375.4255 or email customerservice@thegalley.com for additional guidance on Tap and Tap Accessory placements

Countertop Cutout Plan

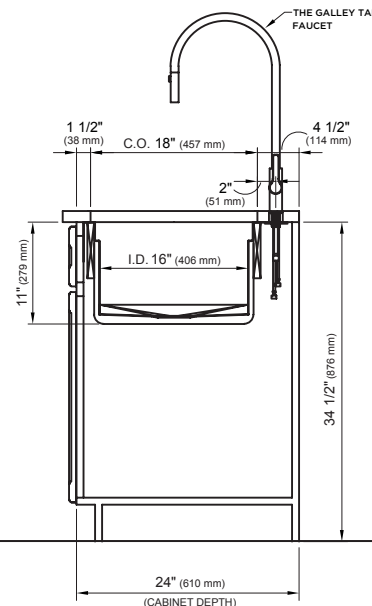
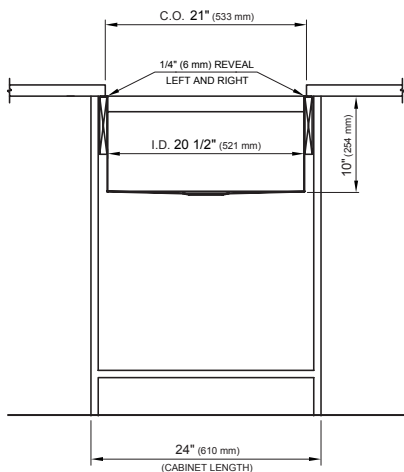

STAINLESS STEEL COMPLIANCE ASME A112. 19.3-2008/CSA B45.4-08

WE RESERVE THE RIGHT TO MAKE REVISIONS WITHOUT NOTICE IN THE DESIGN OF PRODUCTS OR IN PACKAGING UNLESS THIS RIGHT HAS SPECIFICALLY BEEN WAIVED AT THE TIME THE ORDER IS ACCEPTED.

DWG and DXF templates available on our website:

TheGalley.com/specification-library

Questions? For additional assistance, please contact
The Galley's Customer Service Department at 800.375.4255